

Carbon fibre adhesion to organic matrices

J. P. FAVRE, J. PERRIN

Office National d'Etudes et de Recherches Aeronautiques (ONERA), 92-Châtillon, France

It has been possible to measure carbon fibre adhesion to organic resins on single fibres by the "pulling-out" method. Tests were concerned with fibres as-received and following surface treatment. In spite of its limitations, this method provided values in good agreement with the computations of various authors. It can be useful for determining the fibre/interface strength and testing the efficiency of surface treatments.

1. Introduction

The study of the interface between the fibre and the matrix is an essential aspect of research on composite materials reinforced with glass, carbon, boron etc. In the case of carbon fibres in particular, a poor adhesion of the untreated fibre is observed and this adhesion – measured by the short-beam shear strength of the composite – is lower, the higher the Young's modulus of the fibre [1, 2]. Consequently all manufacturers are at present offering varieties so treated as to ensure a stronger bond with the polymer used as a matrix.

We have tried to determine the influence of fibre surface treatments on the strength of this bond and measure the interfacial shear strength, a parameter absolutely necessary for computations, and one that is usually obtained indirectly (e.g. see [3] and [4]).

We have used a single-fibre pull-out technique. This method has already been successfully utilized by Soviet scientists with glass fibres [5,6]. On the other hand Norman, James and Gale [7] were apparently unable to use the method satisfactorily, because the resin obtained was too thick. The technique has also been used in work on glass fibre-reinforced concrete [8], and some measurements have been performed with boron [9] and carbon [10] filaments, aluminium being the matrix in the latter case.

2. Experimental technique

2.1. Specimen fabrication

In her original method Shiriajeva [5] tested a small fibre-resin seam (Fig. 1a). Two small diameter glass rods support the resin which wets

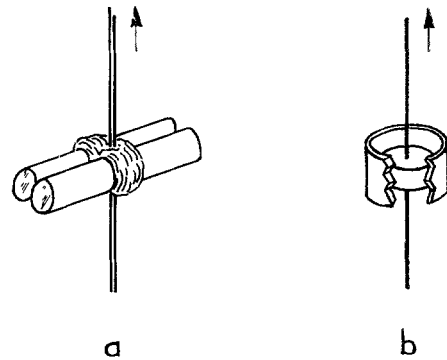

Figure 1 Principle of the method (a) Shiriajeva; (b) modified for carbon fibres.

them completely. Once the resin is cured, the fibre is cut on one side of the seam, then the other end is loaded in tension until pull-out occurs. We have used the same principle with modifications. Since carbon fibres are thinner and more fragile than glass fibres, pull-out may occur only for a thickness of the resin seam far smaller than that which can be obtained with the previous method. The specimen we have used has the following features (Fig. 1b). It is formed in a Duralumin ring with a pastille of resin deposited inside. A carbon fibre (diameter $\sim 8 \mu\text{m}$) has previously been stretched along the ring axis. The Duralumin rings are then partially immersed in mercury and filled up with a small quantity of properly diluted resin. When the resin is cured, each micro-specimen is taken out of the bath. Since mercury forms a rounded surface at the bottom of each ring and resin wets the edges of the ring,

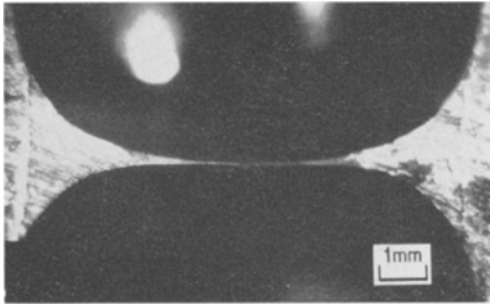

Figure 2 Cross-section of a resin pastille.

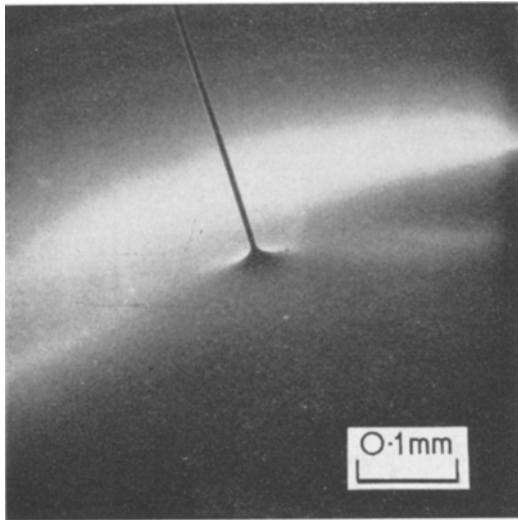

Figure 3 Surface of the micro-specimen prior to traction.

the resin pastille is far thinner at the centre than on the edges and thicknesses of the order of 0.05 mm are obtained (Fig. 2).

The fibres are then pulled-out after removing the lower end of the fibre. Fig. 3 shows the surface of a specimen prior to testing. The existence of a cone-junction is observed between fibre and resin; this resin sheathes the fibre up to a height determined by the wetting conditions.

2.2. Determination of the adhesion strength

The adhesion strength σ_A (in Nmm^{-2}) is given by

$$\sigma_A = \frac{F}{\pi dl}$$

where F is the force required for pull-out, d the diameter of the fibre and l the thickness of the pastille. Actually this is not the thickness that is measured but the length of the withdrawn fibre.

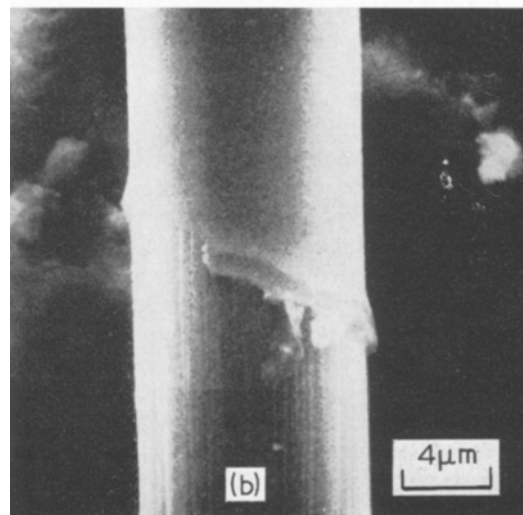
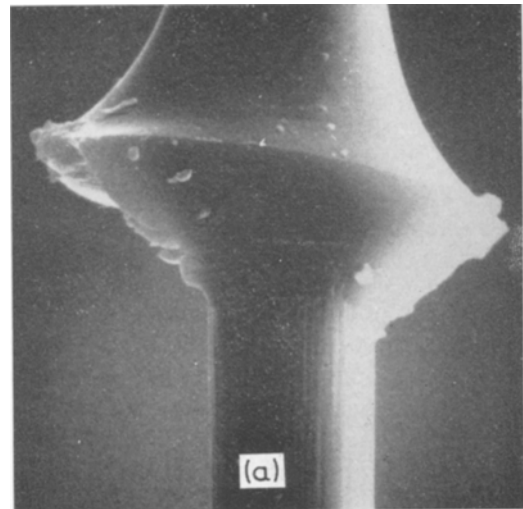

Figure 4 Aspect of Courtaulds HT pulled-out fibres, viewed at the breaking point of the sheath (a) polyester; (b) epoxy.

Indeed the resin sheath breaks away during the pull-out and the bare fibre appears with its characteristic striations. The scanning electron microscope permits the location of the breaking point of the sheath and measurement of the distance between that point and the fibre end, i.e. l . Fig. 4 shows two aspects of withdrawn Courtaulds fibre ends; with a polyester the sheath broke away at the base of the cone-junction (Fig. 4a); with an epoxy, the breaking took place higher up, the resin cone remaining attached to the pastille and in some cases one may find it still adhering (Fig. 5).

The diameter and l are measured at the same

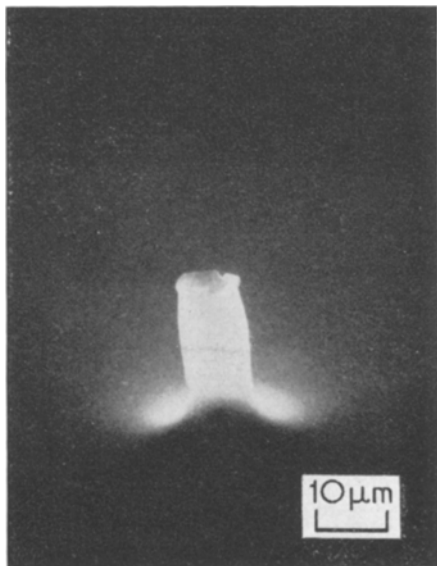

Figure 5 Surface of the micro-specimen after traction and pull-out of the fibre; the resin sheath is still attached to the pastille.

time in the case of cylindrical fibres. For fibres with an irregular shape (bean-shaped fibres for instance) one takes an average cross-section

which is determined elsewhere. Two examples of the sheath breaking away can be seen in Fig. 6 for non-striated cylindrical fibres (Fig. 6a; Columbia University) and for bean-shaped fibres (Fig. 6b; Carbone-Lorraine).

3. Results

3.1. As-received fibres

Table I gives the results of the measurement of σ_A on fibres of various types, as well as the values of the Young's modulus of laboratory-tested lots. All these fibres are in the as-received condition.

The following observations can be made when comparing these values.

For untreated fibres a decrease of σ_A is observed when the modulus increases. This variation is similar to the fall in short-beam shear strength with increasing fibre modulus that has been observed in several investigations. The Columbia University fibres are the only exception in our work, and these would indeed have been expected to have unusually good adhesion, to judge from their low Young's modulus.

The nature of the resin affects the value of σ_A . In particular, the polyimide used has better adhesion than epoxy, which is sometimes difficult to verify on composites.

TABLE I Values of the adhesion strength σ_A for as-received fibres

Fibre	Type	Modulus (GNm ⁻²)	Matrix *	σ_A Nmm ⁻²
Courtaulds	HT (long staple)	270	Polyester A	5.4
			Polyester B	10.4
			Epoxy	9.7
	HTS (continuous tow)	283	Polyimide	17.1
			Epoxy	57.3
	HM (continuous tow)	330 (1st batch)	Epoxy	5.5
Polyimide			12.8	
HMS (continuous tow)	357 (2nd batch) 350	Epoxy	1.8	
		Epoxy	31.4	
Morgan	II treated (sample)	240	Epoxy	41.9
Carbone-Lorraine	AG (short staple)	440	Epoxy	1.0
	AGT (continuous tow)	258	Epoxy	41.6
Columbia	CMR (sample)	42†	Epoxy	8.3

*Polyester A Rhodester 1108 (Rhône-Poulenc)
Polyester B Stratyl A.30 (St Gobain)
Epoxy Araldite LY 556 + HT 972 (CIBA)
Polyimide Kerimid 601 (Rhône-Poulenc)

†Manufacturer's data

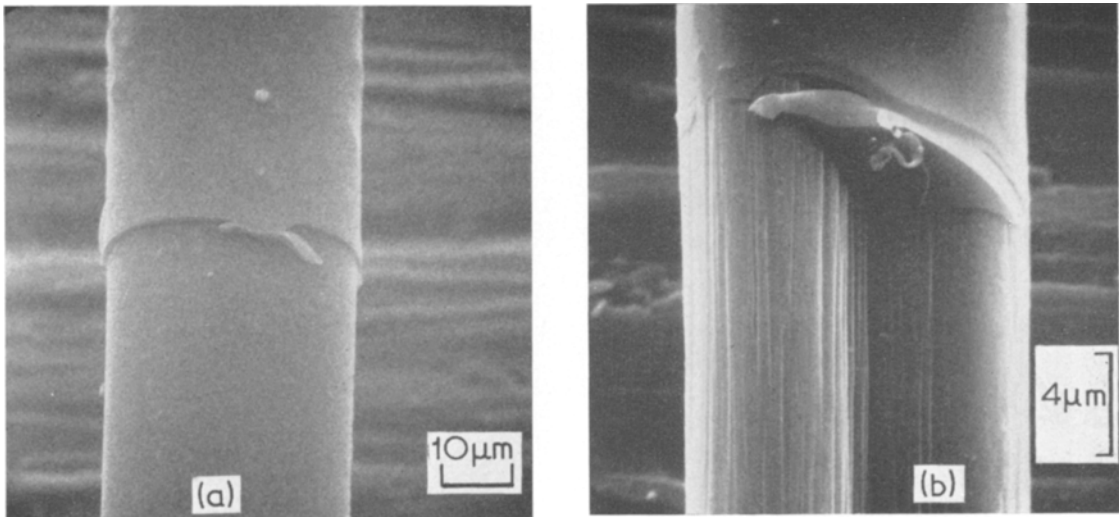

Figure 6 Pull-out aspect for (a) Columbia CMR and (b) Carbone-Lorraine fibres.

All the treatments offered by manufacturers have a noticeable effect on σ_A , which appears to be stronger with weaker fibres.

3.2. Assessment of surface treatments

The effects of surface treatments can easily be checked by this method which requires only a very small quantity of fibres. Examples of treatments applied to Courtauld's fibres are shown in Table II. The tensile modulus and tensile strength of the fibres were measured in each test at the same time as the pull-out.

Table II shows the results of known treatments to increase the shear strength of reinforced materials, in particular those consisting in a slight oxidation of the fibres surface. These processes lead to a considerable increase of σ_A but usually at the expense of noticeable loss of fibre strength, at least for the high-strength type fibres (HT). From these results we see that the three oxidation processes lead to a value of σ_A of the order of 30 to 40 Nmm^{-2} . While oxidation by NaOCl ("anode oxidation") inhibits to some extent the surface attack of the fibre, hot air

TABLE II Adhesion strength of treated fibres (matrix: epoxy LY 556 + HT 972)

Fibre	Treatment	Modulus (GNm^{-2})	Tensile strength (GNm^{-2})	σ_A Nmm^{-2}
Courtaulds HT (long staple)	—	270	2.56	9.7
	benzene washing	270	2.56	7.8
	oxidation (nitric acid)	—	2.14	32.5
	oxidation (hypochlorite)	273.5	2.46	40.0
	oxidation (hot air)	—	1.96	40.5
	formation of silicon carbide	—	—	18.0
Courtaulds HM (continuous)	—	357	1.73	1.8
	oxidation (hypochlorite)	270 to 325	1.00 to 1.80	up to 26
	formation of silicon carbide	281.5	0.88	(70)
	reduction by wet hydrogen	259	1.04	3.8
	pyrolytic carbon coating	—	—	—
	-toluene	340	1.83	8.0
-propylene	—	1.67	8.0 to 46	

oxidation reduces the breaking strength.

As far as the high-modulus type (HM) are concerned the facts are less clear. The fibres are less sensitive to oxidation than the high-modulus ones, which is already well known, but their modulus may vary considerably with the type of treatment. Among the other treatments carried out to "activate" the surface of the fibres, the action of silicon and that of hydrogen have been quoted. Both lead to a noticeable "eating away" of the fibre which loses its mechanical properties. The improvement in adhesion is erratic.

Coatings constitute the last kind of treatments proposed. In this work coating with pyrolytic carbon from various hydrocarbons was studied. These coatings form a skin around the fibres, to which resin adheres better than to the fibre (Fig. 7), and values as high as 46 Nmm^{-2} were reached by pyrolysis of propylene. Furthermore this method has the advantage of not damaging the fibre and one may even find a slight increase in tensile strength.

4. Limitations of the method

4.1. Experimental scatter

Since single filaments are used and the number of measurements is limited, the scatter of results is of some importance. A statistical review of the HT/epoxy basic system provided values included between 4.4 and 17.4 with a mean value of 9.7 Nmm^{-2} (27 measurements, coefficient of variation = 38%). However the distribution of these values around the mean value follows a normal law. In every case, scatter is always greater for as-received fibres.

But if the fibres are washed, there is always a reduction of the scatter. For example, for the same fibre/matrix system after washing the fibre at length with benzene, the extreme values are 6 and 10 Nmm^{-2} with a mean value of 7.8 (Table II). It would appear that there has been a cleaning of the surface layers which have slowly oxidized with time. This oxidation improves adhesion (9.7 Nmm^{-2} instead of 7.8) but it is probably irregular (coefficient of variation 38% instead of 18% for washed fibres). This reduction of the dispersion is very generally observed when the treatment uses a liquid. On the other hand, in the case of vapour-deposited coatings (pyrolytic carbon for example), it is of prime importance to obtain a regular and homogeneous coating.

4.2. Strong adhesion

When the interface strength becomes too high,

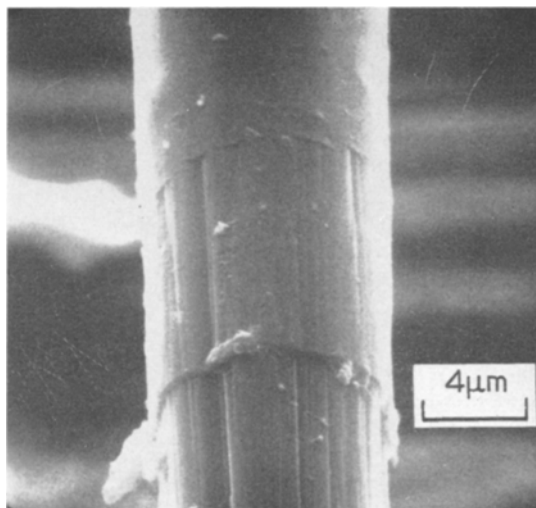

Figure 7 View of a pulled-out Courtaulds HM fibre covered with pyrolytic carbon (origin: toluene).

one notes an increasingly higher percentage of broken fibres without pull-out, and a larger experimental scatter. Furthermore, for a load too close to its ultimate value, the fibre cannot withstand the consequence of the sudden fall in tension and it disintegrates, even when a pull-out occurs. This explains the relation that may have been noticed between the adhesion strength σ_A of fibres subjected to various treatments, and $1/l$ (or better $1/\Omega$, Ω being the total surface of resin imbedded fibre): it results only from the fact that, when imbedded lengths are too large the fibre breaks prior to pull-out and therefore there is no recorded result. Utilizing fibres with a larger cross-section and a higher ultimate load would correct this drawback.

5. Conclusions

Wadsworth and Spilling [4] have determined an interface strength of 6 Nmm^{-2} in the case of poor adhesion for high modulus carbon fibres, and 47 Nmm^{-2} in that of a solid interface, probably obtained through a controlled oxidation of the fibres.

These values are not very different from those found here: 2 to 5.5 for clean, high modulus fibres and 31.4 for treated ones (see Table I). These differences must be referred to some estimates made by those authors as well as to end-effects which are certainly present in our experiments (existence of a cone-junction on one

side and possibly of a badly cut-off fibre on the other).

Some questions remain unanswered. First, what is the pull-out process in this specific kind of test? According to Bowden's interpretation [11], one would suppose that a crack originates in the cone-junction, where stress concentrations are the highest. The point where this failure starts varies with the type of resin (it is shown on Fig. 4). The crack reaches the interface and extends along the fibre.

This would also explain the fact that in the cases when resin wets the fibres only poorly and the sheath around is too thick, the required load to extract it from the matrix is not higher than in the case of a very thin sheath (adequate wetting). Attempting to correct the total strength by taking into account the specific resistance of the resin sheath, has always been unsuccessful.

Second, is it possible to detect slipping in the resin after interface failure? The numerous experiments with large diameter filaments (tungsten, steel etc.) or with glass bars have always shown the existence of an important residual friction stress after a first maximum: this friction should also appear here. The origin of some irregularities in the last part of the load-extension recordings could perhaps be explained in this way.

If thicker high modulus carbon fibres could be obtained these points could probably be quickly clarified.

Acknowledgements

We are grateful to "Le Carbone Lorraine" for the samples of treated fibres made available to us and to Mr Hawthorne from the University of British Columbia, who sent us fibres obtained from pitch.

References

1. S. P. PROSEN and R. A. SIMON, *Plastics and Polymers* **36** (1968) 241.
2. R. A. SIMON, S. P. PROSEN, and J. DUFFY, *Nature* **213** (1967) 1113.
3. P. HANCOCK and R. C. CUTHBERTSON, *J. Mater. Sci.* **5** (1970) 762.
4. N. J. WADSWORTH and I. SPILLING, *Brit. J. Appl. Phys. (J. Phys. D.)* **S2 1** (1968) 1049.
5. G. V. SHIRIAJEVA and G. D. ANDREEVSKAYA, *Sov. Plastics* no. 4 (1962) 40.
6. G. D. ANDREEVSKAYA and YU. A. GORBATKINA, Proc. Ann. Conf., Soc. Plastics Ind., Reinf. Plastics/Compos. Div. 1970, section 16 F.
7. R. H. NORMAN, D. I. JAMES, and G. N. GALE, *Chem. Eng.* **182** (1964) 243.
8. R. C. DE VEKEY and A. J. MAJUMDAR, *Mag. Concrete Res.* **20** (1968) 229.
9. J. MULLER, *Deut. Luft- und Raumfahrt, DLR-Forschungsbericht* **69-29** (1969).
10. F. J. SCHMIDT *et al*, 15th Nat. Sampe Symp. and Exhib., Los Angeles, April 1969.
11. P. B. BOWDEN, *J. Mater. Sci.* **5** (1970) 517.

Received 25 January and accepted 14 March 1972.